

DEARBORN



REMOTE CONTROL ATTACHMENTS

MODELS 23-9 AND 23-11



ASSEMBLY AND OPERATING INSTRUCTIONS



Remote Control Attachments in Use

The Dearborn Remote Control Attachments consist of the Remote Control Valve, Model 23-9, and the Remote Control Attachment, Model 23-11. Both of these attachments have been designed for use with the Model NAA Ford Tractor.

The Remote Control Valve, Model 23-9, when installed, directs the flow of oil from the tractor hydraulic system to the hydraulic cylinder of the Remote Control Attachment, Model 23-11. The valve control lever is conveniently located at the rear of the valve and within easy reach of the tractor operator.

The Remote Control Attachment, Model 23-11, consists of a double acting cylinder, designed in accordance with A.S.A.E. (American Society of Agricultural Engineers) standards, hydraulic hoses, brackets, and a safety breakaway coupling. The cylinder can be mounted on various implements and is used for applications such as hydraulic adjustments on combine headers, grain drill openers, and disc harrows.

The Remote Control Attachment breakaway coupling provides a safety device as well as a convenient time saving feature. In the event that the implement becomes detached during operation, the coupling will separate when a pull of eighty-five pounds is applied. An automatic closing device within the coupling prevents the loss of oil or dirt from entering the oil lines.

This manual contains information on the assembly, operation, and adjustments of the Dearborn Remote Control Attachments. Read it carefully, study the illustrations and keep it available for ready reference.

RESPONSIBILITY OF DEALER

The installation of the Dearborn Remote Control Attachments, Models 23-9 and 23-11, on the Model NAA Ford Tractor is the responsibility of the Dearborn Farm Equipment dealer. The dealer will show the purchaser how to operate and adjust the Remote Control Attachments. The following instructions are provided in case of need.

DEARBORN MOTORS CORPORATION

National Marketing Organization for the Ford Tractor and Dearborn Equipment

BIRMINGHAM, MICHIGAN

REMOTE CONTROLS

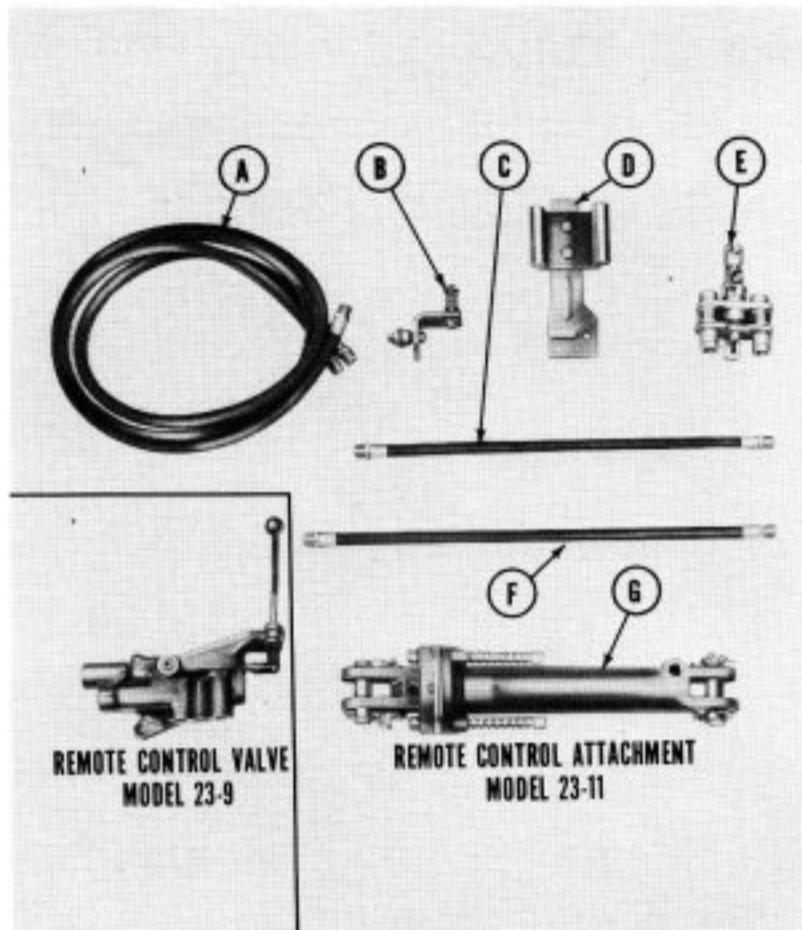

Figure 1

Remote Control Attachment Parts

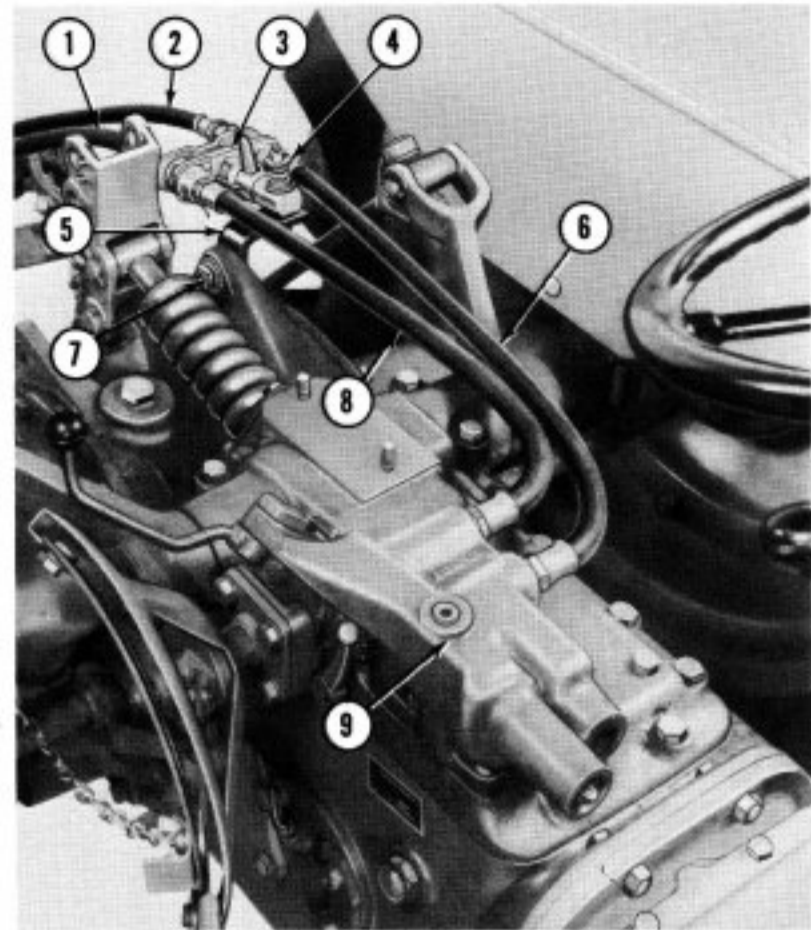

Figure 2

Remote Control Valve on the Model NAA Ford Tractor

SHIPPING INFORMATION

The Dearborn Remote Control Attachments, Models 23-9 and 23-11, are sold separately and shipped in separate cartons. The following list and Figure 1 show the parts included in the attachments. The Remote Control Valve, Model 23-9, see insert, Figure 1, is shipped in one carton (D.M.C. Bundle No. 23-9), which contains the valve, two studs, two nuts, and five "O" rings.

The Remote Control Attachment, Model 23-11, (See Figure 1) is also shipped in one carton (D.M.C. Bundle No. 23-11) which contains the following parts:

Item	Description	Required
A.	Hoses—Coupling to cylinder	2
B.	Bracket—Coupling to tractor	1
C.	Hose, short—Valve to coupling	1
D.	Bracket—Tractor fender	1
E.	Breakaway Coupling	1
F.	Hose, long —Valve to coupling	1
G.	Cylinder assembly	1

REMOTE CONTROL VALVE MODEL 23-9

Install the Remote Control Valve on the Model NAA Ford Tractor as follows:

1. Remove the tractor seat and manifold plate from the tractor hydraulic lift cover.
2. Insert the two studs, provided with the valve, in the outer edge of the lift cover. These studs replace the two cap screws which were used to attach the manifold plate.

NOTE: On tractors which have cap screws securing the manifold plate, it will be necessary to replace all the cap screws with Studs, Part No. 358579-S2 and Nuts, Part No. 33792-S2.

3. Insert the "O" rings in the counterbores of the valve, making sure that they are properly located. Note that two "O" rings are larger than the others. Secure the valve (9) to the tractor hydraulic lift cover as shown in Figure 2.
4. Re-install the tractor seat.

REMOTE CONTROLS

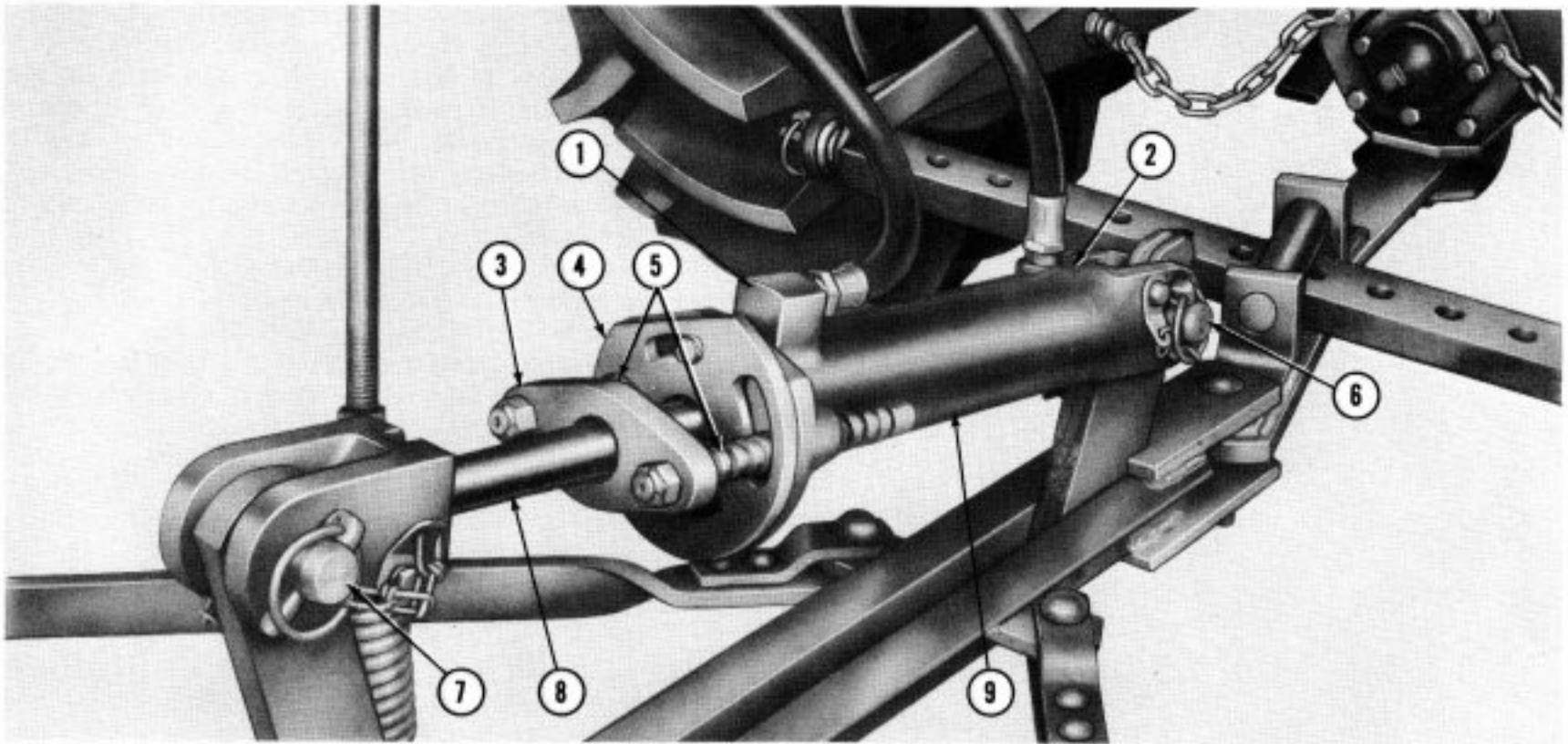

Figure 3
The Remote Control Cylinder Attached

REMOTE CONTROL ATTACHMENT MODEL 23-11

Install the Remote Control Attachment on the Model NAA Ford Tractor with the Remote Control Valve as follows:

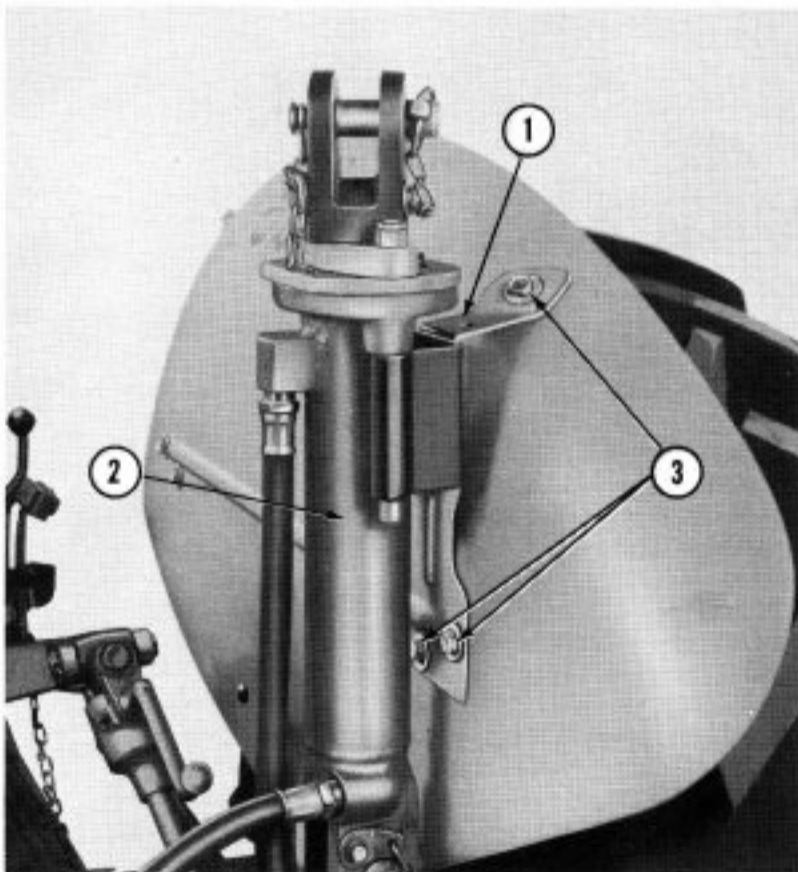

Figure 4
Fender Bracket and Cylinder

1. Turn the short hose (8), Figure 2, and long hose (6) into the valve parts as shown.
2. Attach the bracket (5), Figure 2, to the tractor center housing with the bolt (7), bushing, flatwasher and nut provided.
3. Attach the hoses (6) and (8), Figure 2, to the coupling (3) as shown. Secure the coupling to the bracket (5) with the bolt (4), flatwashers, spring and nut as shown.
4. Attach the two long hoses (1) and (2), Figure 2, to the rear fittings of the coupling (3).
5. Attach the other end of the right hose (1), Figure 2, to the lower port (2), Figure 3, in the cylinder.
6. Attach the left hose (2), Figure 2, to the upper port (1), Figure 3, in the cylinder.

NOTE: The hoses must be attached to the cylinder as outlined above to obtain satisfactory operation of the cylinder and control valve.

7. Attach the cylinder to the brackets on the implement with the pins (6) and (7) and linch pins as shown in Figure 3.
8. Attach the bracket (1), Figure 4, to the right tractor fender with the three bolts (3). When not in use, the cylinder (2), Figure 4, should be placed in this bracket as shown for transport.

OPERATION

The Remote Control Valve, Model 23-9, is used to direct oil from the tractor hydraulic system to the Remote Control Cylinder. To operate the cylinder, push the valve control lever rearward. It is not necessary to hold the lever, as it will lock in position until the cylinder piston rod has been fully extended or retracted. If desired, the travel of the rod may be stopped

REMOTE CONTROLS

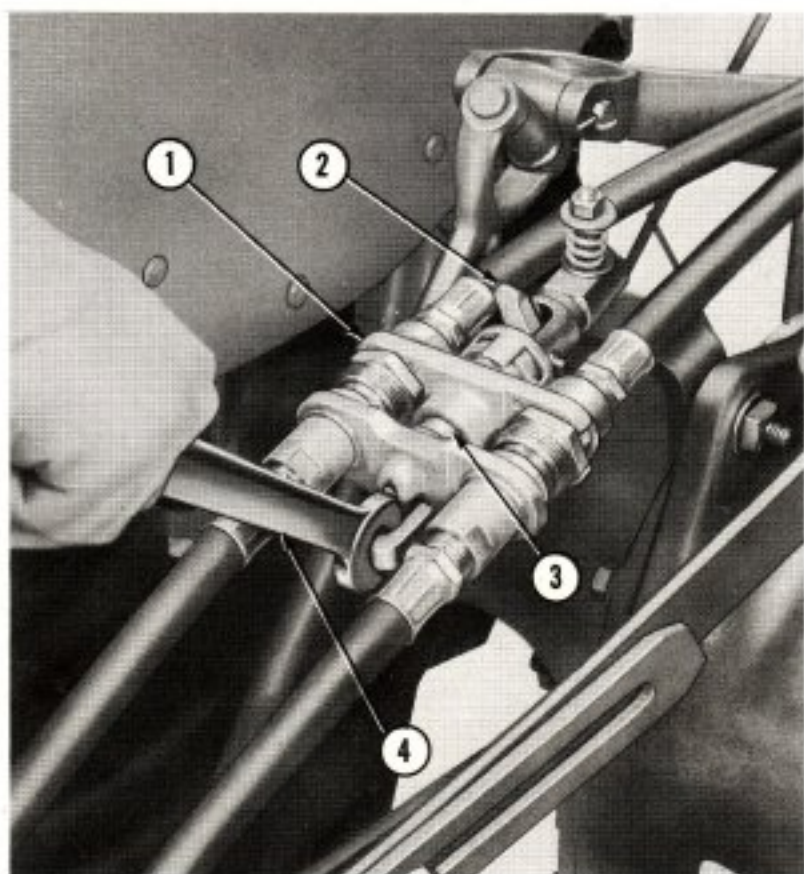

Figure 5
Breakaway Coupling

before its full extent of travel by pulling the lever back to the neutral position. The cylinder piston rod is retracted by pushing the lever forward. When only a short movement of the piston rod is desired, the valve lever may be feathered until the desired adjustment is obtained.

The Remote Control Attachment, Model 23-11, is used with the Remote Control Valve and has many applications on various farm implements. The breakaway coupling (1), Figure 5, provides two important features to users of modern hydraulically controlled farm equipment. It permits quick, easy connecting or disconnecting of hydraulically controlled farm implements and eliminates breaking of the hose lines and losing oil in the event that the implement breaks away from the tractor.

The breakaway coupling consists of four self-sealing coupling halves mounted in frames which are held in a coupled position by a mechanical latch. The couplings may be separated automatically by a pull on either hose line attached to the implement, or manually by moving the release (2), Figure 5, towards the rear. To reattach the halves of the coupling, clean the ends thoroughly and insert the frame (3), Figure 5, on the rear half of the coupling into the front half of the coupling. Use a wrench (4), Figure 5, or screw driver as a lever to pry the halves of the coupling together.

ADJUSTMENTS

Stroke of Piston Rod: The length of the piston rod stroke may be adjusted by turning the lock plates (4), Figure 3, and pulling the stop (3) out to the desired position. Lock the two graduated rods (5) in position with the lock plates (4), Figure 3.

MAINTENANCE

Your Ford Tractor and Dearborn Farm Equipment dealer stocks genuine Ford Tractor and Dearborn Farm Equipment repair parts. These parts are precision manufactured and inspected to assure high quality and accurate fit. Insist on genuine Ford Tractor and Dearborn Farm Equipment repair parts.

DEARBORN MOTORS CORPORATION

EQUIPMENT WARRANTY

DEARBORN MOTORS CORPORATION warrants all parts (other than pneumatic tires, inner tubes and batteries) of equipment bearing the trade-mark "Dearborn" to the original purchaser thereof at retail, for a period of six (6) months from the date of delivery thereof to the original purchaser at retail, to be free from defects in workmanship and material under normal use and service. The obligation of Dearborn Motors Corporation under this warranty shall be limited to shipment, without charge to the original purchaser at retail, of the part or parts of such Dearborn Equipment intended to replace the part or parts acknowledged by Dearborn Motors Corporation to be defective in workmanship or material. This warranty is in lieu of all other warranties, expressed or implied, and of all obligations or liabilities on the part of Dearborn Motors Corporation, and it neither assumes nor authorizes any person to assume for it, any other obligation or liability in connection with workmanship or material of equipment bearing the trade-mark "Dearborn" or any part thereof. This warranty shall not apply to any Dearborn Equipment, or any part thereof, which has been damaged in any accident, or by fire, flood, or Act of God, or abused or misused, or which has been altered elsewhere than at the place of manufacture, or in which the original purchaser thereof at retail, has used or allowed to be used, parts not made or supplied by Dearborn Motors Corporation. Dearborn Motors Corporation reserves the right at any time to make changes in the design, materials and/or specifications of equipment bearing the trade-mark "Dearborn" and/or accessories, therefor, without thereby becoming liable to make similar changes in equipment bearing the trade-mark "Dearborn" and/or accessories therefor, previously manufactured.

DEARBORN MOTORS CORPORATION

National Marketing Organization for the Ford Tractor and Dearborn Equipment

Birmingham, Michigan